

# HYRD Technical Bulletin

This technical bulletin is for HYRD owners who received brakes from June 01, 2013 to current date.

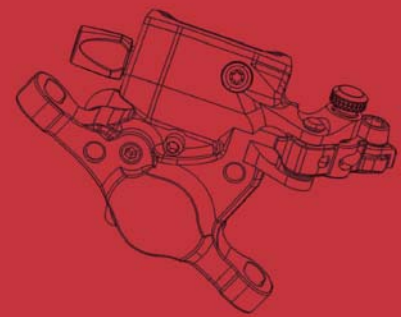

The HYRD brake system is an open hydraulic brake designed for use on single rider bicycles. The purpose of the open hydraulic system is to allow the pistons to compensate for pad wear. Each time the brake is released, the piston opens up the reservoir, allowing more oil into the caliper if needed. Only a properly set-up brake will allow the piston to retract fully ensuring that your brakes can account for worn pads.

The barrel adjuster is intended to fine tune cable tension to take up cable slack that some people find difficult to remove when installing the cable.

The barrel adjuster has a **1.5 turn limit** before the system is closed off. When using the barrel adjuster, check that the Lock Knob will still thread into the actuator arm, (with a brake lever in the released state.)

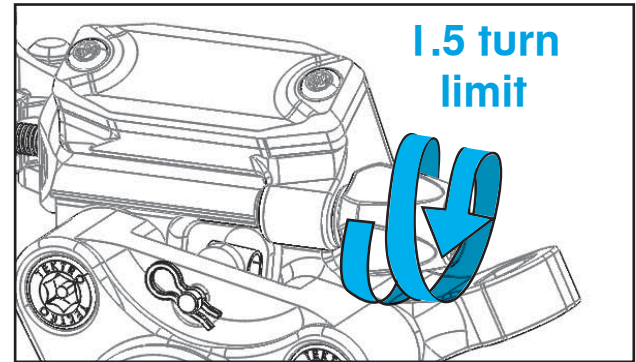

## Routine function check

To check if your brake has been set-up and is operating correctly, examine the Lock Knob feature next to the cable actuator arm. If the Lock Knob can be threaded into arm, then this means the actuator arm is in the correct position and the hydraulic system is open.

If the Lock Knob will **NOT** thread into the actuator arm or is very difficult, this means that the actuator arm is preventing the piston from returning fully and has closed off the reservoir port. This prevents the brake to compensate for pad wear.

To remedy this - follow the cable installation and adjust instructions in the HYRD Owner's Manual.

**DO NOT RIDE A BIKE WITH A BRAKE IN THIS CONDITION. IT COULD CREATE A POTENTIALLY DANGEROUS SITUATION, PARTICULARLY WITH WORN PADS.**

*TRP does not recommend the use of inline barrel adjusters. These are for use on mechanical brakes to compensate for pad wear. Using inline barrel adjusters will increase the risk of accidentally riding with a closed system.*

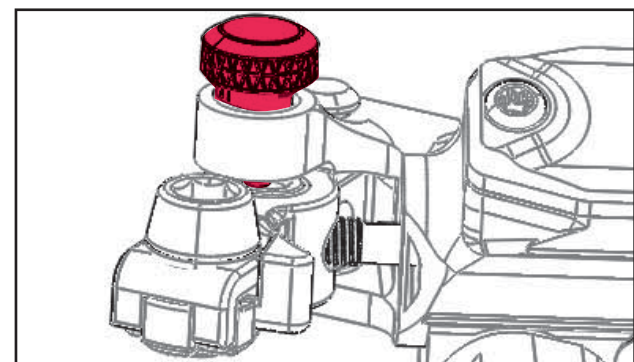
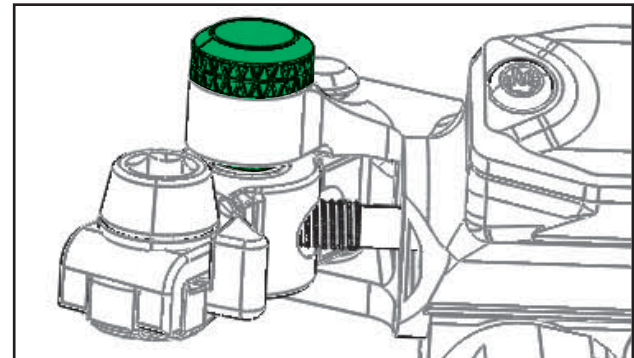

For questions about setup, usage or general inquiries, please contact TRP by e-mail at [info@trpbrakes.com](mailto:info@trpbrakes.com)

or  
by phone toll free in US, 877-807-4162 or outside US 1-801-648-7079.